

HIGH VOLTAGE FASTSWITCHING NPN POWER TRANSISTOR

- SGS-THOMSON PREFERRED SALESTYPES
- HIGH VOLTAGE CAPABILITY
- VERY HIGH SWITCHING SPEED

APPLICATIONS:

- SWITCH MODE POWER SUPPLIES

DESCRIPTION

The SGSF324 is manufactured using Multiepitaxial Mesa technology for cost-effective high performance and uses a Hollow Emitter structure to enhance switching speeds.

The SGSF series is designed for high speed switching applications such as power supplies and horizontal deflection circuits in TVs and monitors.

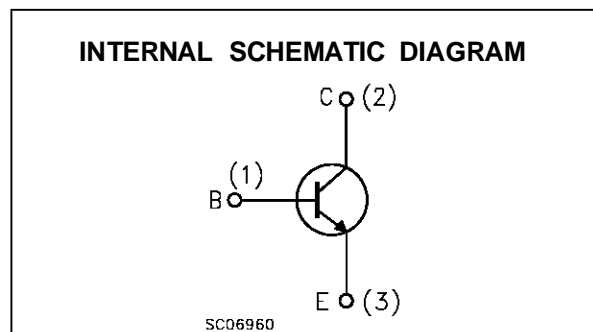
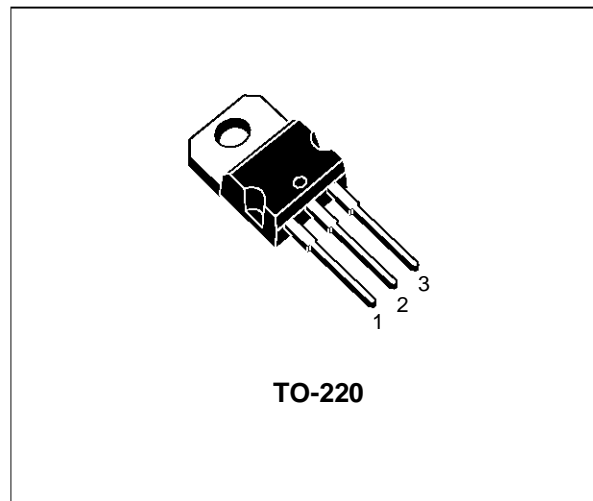

ABSOLUTE MAXIMUM RATINGS

Symbol	Parameter	Value	Unit
V_{CES}	Collector-Emitter Voltage ($V_{BE} = 0$)	1200	V
V_{CEO}	Collector-Emitter Voltage ($I_B = 0$)	600	V
V_{EBO}	Emitter-Base Voltage ($I_C = 0$)	7	V
I_C	Collector Current	4	A
I_{CM}	Collector Peak Current ($t_p < 5$ ms)	8	A
I_B	Base Current	3	A
I_{BM}	Base Peak Current ($t_p < 5$ ms)	6	A
P_{tot}	Total Dissipation at $T_c = 25$ °C	70	W
T_{stg}	Storage Temperature	-65 to 150	°C
T_j	Max. Operating Junction Temperature	150	°C

THERMAL DATA

R _{thj-case}	Thermal Resistance Junction-Case	Max	1.78	°C/W
R _{thj-amb}	Thermal Resistance Junction-Ambient	Max	62.5	°C/W

ELECTRICAL CHARACTERISTICS (T_{case} = 25 °C unless otherwise specified)

Symbol	Parameter	Test Conditions	Min.	Typ.	Max.	Unit
I _{CES}	Collector Cut-off Current (V _{BE} = 0)	V _{CE} = 1200 V			200	μA
I _{CEO}	Collector Cut-off Current (I _B = 0)	V _{EC} = 380 V V _{EC} = 600 V			200	μA mA
I _{EBO}	Emitter Cut-off Current (I _C = 0)	V _{BE} = 7 V			1	mA
V _{CEO(sus)*}	Collector-Emitter Sustaining Voltage	I _C = 100 mA	600			V
V _{CE(sat)*}	Collector-Emitter Saturation Voltage	I _C = 1.75 A I _B = 0.35 A I _C = 1.25 A I _B = 0.18 A			1.5 1.5	V V
V _{BE(sat)*}	Base-Emitter Saturation Voltage	I _C = 1.75 A I _B = 0.35 A I _C = 1.25 A I _B = 0.18 A			1.5 1.5	V V
t _{ON} t _s t _f	Turn-on Time Storage Time Fall Time	RESISTIVE LOAD V _{CC} = 250 v I _C = 1.75 A I _{B1} = 0.35 A I _{B1} = - 0.7 A		0.6 3 0.2	1 4.5 0.35	μs μs μs
t _{ON} t _s t _f	Turn-on Time Storage Time Fall Time	RESISTIVE LOAD V _{CC} = 250 v I _C = 1.75 A I _{B1} = 0.35 A I _{B1} = - 0.7 A With Antisaturation Network		0.6 2 0.16		μs μs μs
t _{ON} t _s t _f	Turn-on Time Storage Time Fall Time	RESISTIVE LOAD V _{CC} = 250 V I _C = 1.75 A I _{B1} = 0.35 A V _{BE(off)} = - 5 V		0.6 1 0.5		μs μs μs
t _s t _f	Storage Time Fall Time	INDUCTIVE LOAD I _C = 1.75 A h _{FE} = 5 V _{CL} = 450 V V _{BE(off)} = -5 V L = 300 μH R _{BB} = 2 Ω		1.2 0.1	2.5 0.2	μs μs
t _s t _f	Storage Time Fall Time	INDUCTIVE LOAD I _C = 1.75 A h _{FE} = 5 V _{CL} = 450 V V _{BE(off)} = -5 V L = 300 μH R _{BB} = 2 Ω T _c = 100 °C			3.7 0.3	μs μs

* Pulsed: Pulse duration = 300 μs, duty cycle 1.5 %

Safe Operating Area Thermal Impedance

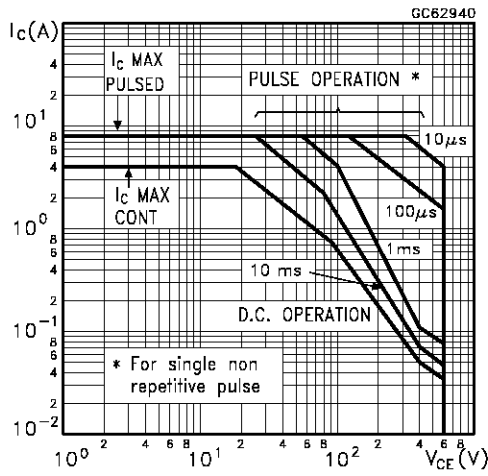

Derating Curve

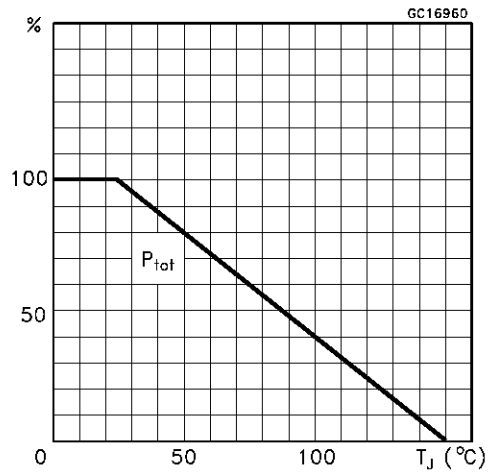

DC Current Gain

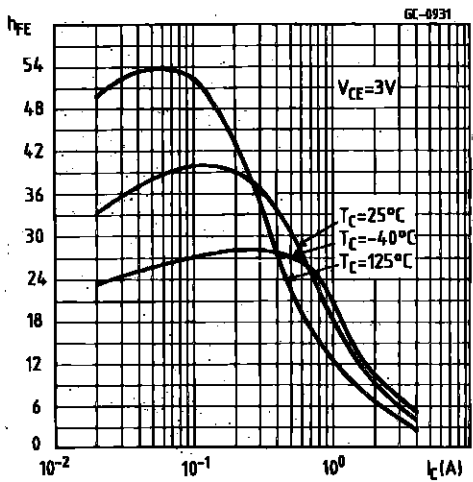

Collector Emitter Saturation Voltage

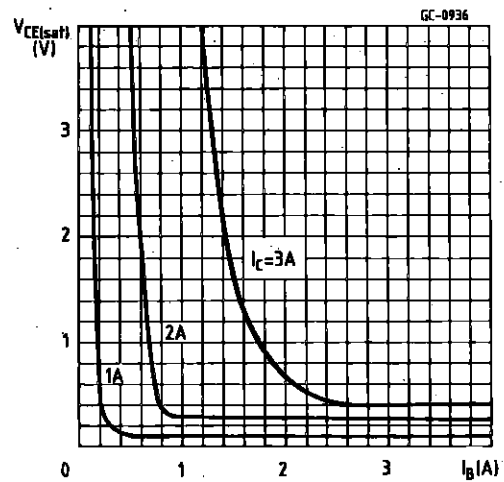

Collector Emitter Saturation Voltage

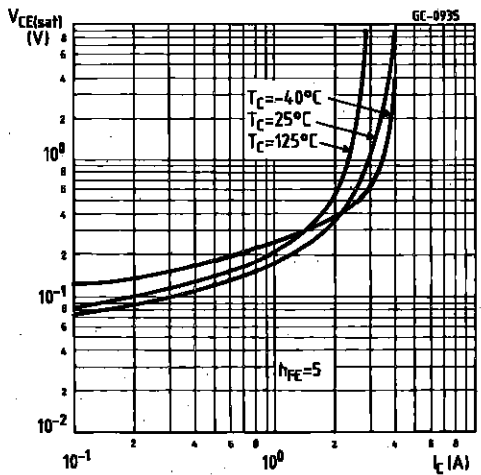

Base Emitter Saturation Voltage

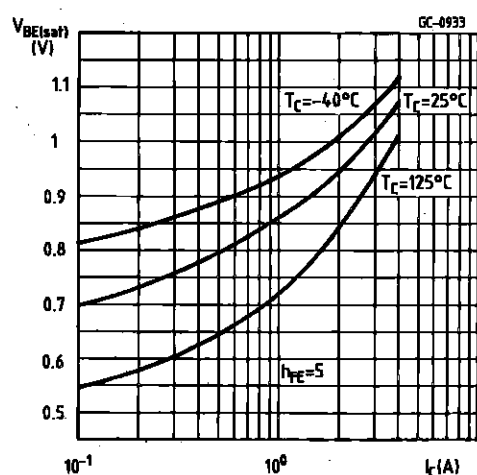

Resistive Load Switching Times

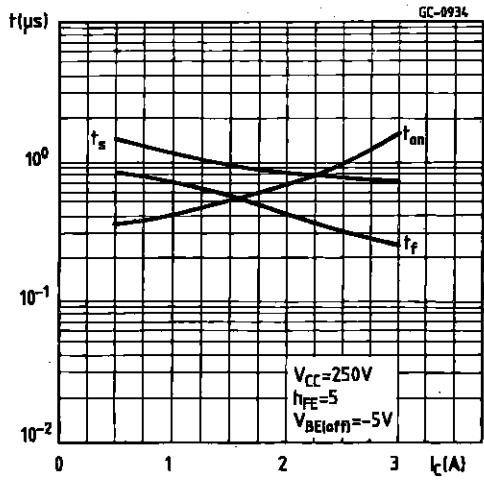

Resistive Load Switching Times

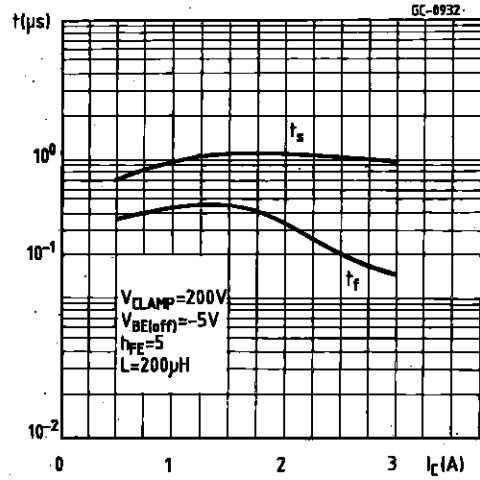

Switching Times Percentance Variation

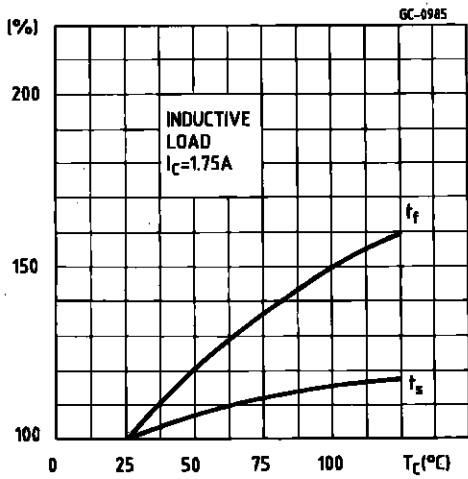

Reverse Biased SOA

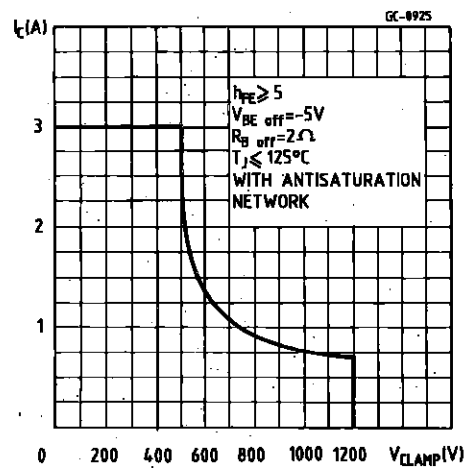

TO-220 MECHANICAL DATA

DIM.	mm			inch		
	MIN.	TYP.	MAX.	MIN.	TYP.	MAX.
A	4.40		4.60	0.173		0.181
C	1.23		1.32	0.048		0.051
D	2.40		2.72	0.094		0.107
D1		1.27			0.050	
E	0.49		0.70	0.019		0.027
F	0.61		0.88	0.024		0.034
F1	1.14		1.70	0.044		0.067
F2	1.14		1.70	0.044		0.067
G	4.95		5.15	0.194		0.203
G1	2.4		2.7	0.094		0.106
H2	10.0		10.40	0.393		0.409
L2		16.4			0.645	
L4	13.0		14.0	0.511		0.551
L5	2.65		2.95	0.104		0.116
L6	15.25		15.75	0.600		0.620
L7	6.2		6.6	0.244		0.260
L9	3.5		3.93	0.137		0.154
DIA.	3.75		3.85	0.147		0.151

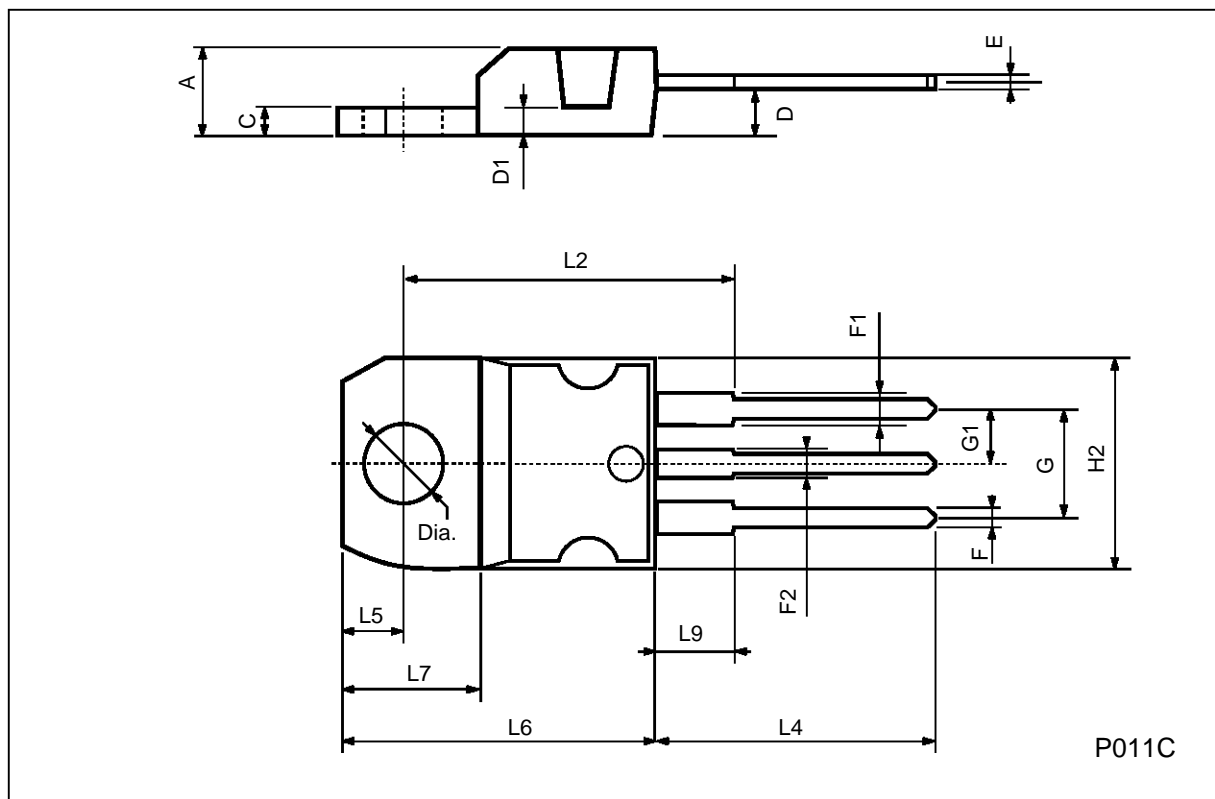

Information furnished is believed to be accurate and reliable. However, SGS-THOMSON Microelectronics assumes no responsibility for the consequences of use of such information nor for any infringement of patents or other rights of third parties which may result from its use. No license is granted by implication or otherwise under any patent or patent rights of SGS-THOMSON Microelectronics. Specifications mentioned in this publication are subject to change without notice. This publication supersedes and replaces all information previously supplied. SGS-THOMSON Microelectronics products are not authorized for use as critical components in life support devices or systems without express written approval of SGS-THOMSON Microelectronics.

© 1995 SGS-THOMSON Microelectronics - Printed in Italy - All Rights Reserved

SGS-THOMSON Microelectronics GROUP OF COMPANIES

Australia - Brazil - Canada - China - France - Germany - Hong Kong - Italy - Japan - Korea - Malaysia - Malta - Morocco - The Netherlands - Singapore - Spain - Sweden - Switzerland - Taiwan - Thailand - United Kingdom - U.S.A